



**PORTABLE CD PLAYER
WITH AM/FM STEREO RADIO**



USER MANUAL

CD-475

**PLEASE READ THIS USER MANUAL COMPLETELY BEFORE OPERATING
THIS UNIT AND RETAIN THIS BOOKLET FOR FUTURE REFERENCE.**

DEAR JENSEN® CUSTOMER

Selecting fine audio equipment such as the unit you've just purchased is only the start of your musical enjoyment. Now it's time to consider how you can maximize the fun and excitement your equipment offers. This manufacturer and the Electronic Industries Association's Consumer Electronics Group want you to get the most out of your equipment by playing it at a safe level. One that lets the sound come through loud and clear without annoying blaring or distortion and, most importantly, without affecting your sensitive hearing.

Sound can be deceiving. Over time your hearing "comfort level" adapts to higher volumes of sound. So what sounds "normal" can actually be loud and harmful to your hearing. Guard against this by setting your equipment at a safe level BEFORE your hearing adapts.

To establish a safe level:

- Start your volume control at a low setting.
- Slowly increase the sound until you can hear it comfortably and clearly, and without distortion.

Once you have established a comfortable sound level:

- Set the dial and leave it there.

Taking a minute to do this now will help to prevent hearing damage or loss in the future. After all, we want you listening for a lifetime.

We Want You Listening For a Lifetime

Used wisely, your new sound equipment will provide a lifetime of fun and enjoyment. Since hearing damage from loud noise is often undetectable until it is too late, this manufacturer and the Electronic Industries Association's Consumer Electronics Group recommend you avoid prolonged exposure to excessive noise.

Customer's Record:



The serial number of this product is found on its bottom. You should note the serial number of this unit in the space provided as a permanent record of your purchase to aid in identification in the event of theft or loss.

Model Number: CD-475

Serial Number: _____

WARNING

TO PREVENT FIRE OR SHOCK HAZARD, DO NOT USE THIS PLUG WITH AN EXTENSION CORD, RECEPTACLE OR OTHER OUTLET UNLESS THE BLADES CAN BE FULLY INSERTED TO PREVENT BLADE EXPOSURE. TO PREVENT FIRE OR SHOCK HAZARD, DO NOT EXPOSE THIS APPLIANCE TO RAIN OR MOISTURE.

 <p>The lightning flash and arrow head within the triangle is a warning sign alerting you of "dangerous voltage" inside the product.</p>	<p style="text-align: center;">CAUTION RISK OF ELECTRIC SHOCK DO NOT OPEN</p> <p>CAUTION: TO REDUCE THE RISK OF ELECTRIC SHOCK DO NOT REMOVE COVER (ON BACK), NO USER SERVICEABLE PARTS INSIDE. REFER SERVICING TO QUALIFIED SERVICE PERSONNEL.</p>	 <p>The exclamation point within the triangle is a warning sign alerting you of important instructions accompanying the product.</p>
---	--	---

The Caution Marking is located at the bottom enclosure of the apparatus.

IMPORTANT SAFETY INSTRUCTIONS

1. Read these instructions.
2. Keep these instructions.
3. Heed all warnings.
4. Follow all instructions.
5. Do not use this apparatus near water.
6. Cleaning-Unplug this product from the wall outlet before cleaning. Do not use liquid cleaners or aerosol cleaners. Clean only with dry cloth.
7. Do not block any ventilation openings. Install in accordance with the manufacturer's instructions.
8. Do not place this product on an unstable cart, stand, tripod, bracket, or table. The product may fall, causing serious injury to a child or adult, and serious damage to the product. Use only with a cart, stand, tripod, bracket, or table recommended by the manufacturer, or sold with the product. Any mounting of the product should follow the manufacturer's instructions, and should use a mounting accessory recommended by the manufacturer. A product and cart combination should be moved with care-quick stops, excessive force and uneven surfaces may cause the product and cart combination to overturn.
9. Do not install near any heat sources such as radiators, heat registers, stoves, or other apparatus (including amplifiers) that product heat.
10. Do not defeat the safety purpose of the polarized or grounding-type plug. A polarized plug has two blades with one wider than the other. A grounding type plug has two blades and a third grounding prong. The wide blade or the third prong is provided for your safety. If the provided plug does not fit into your outlet, consult an electrician for replacement of the obsolete outlet.
11. Protect the power cord from being walked on or pinched particularly at plugs, convenience receptacles, and the point where they exit from the apparatus.
12. Only use attachments/accessories specified by the manufacturer.
13. Unplug this apparatus during lightning storms or when unused for a long periods of time.
14. Refer all servicing to qualified service personnel. Servicing is required when the apparatus has been damaged in any way, such as power-supply cord or plug is damaged, liquid has



been spilled or objects have fallen into the apparatus, the apparatus has been exposed to rain or moisture, does not operate normally, or has been dropped.

15. This appliance shall not be exposed to dripping or splashing water and that no object filled with liquids such as vases shall be placed on the apparatus.
16. Do not overload wall outlet. Use only power source as indicated.
17. Use replacement part as specified by the manufacturer.
18. Upon completion of any service or repairs to this product, ask the service technician to perform safety checks.
19. Power Sources - This product should be operated only from the type of power source indicated on the marking label. If you are not sure of the type of power supply to your home, consult your product dealer or local power company. For products intended to operate from battery power, or other sources, refer to the operating instruction.
20. Object and Liquid Entry - Never push objects of any kind into this product through openings as they may touch dangerous voltage points or short-out parts that could result in a fire or electric shock. Never spill liquid of any kind on the product.
21. Damage Requiring Service - Unplug this product from the wall outlet and refer servicing to qualified service personnel under the following conditions:
 - a) When the power-supply cord or plug is damaged,
 - b) If liquid has been spilled, or objects have fallen into the product,
 - c) If the product has been exposed to rain or water,
 - d) If the product does not operate normally by following the operating instructions. Adjust only those controls that are covered by the operating instructions as an improper adjustment of other controls may result in damage and will often require extensive work by a qualified technician to restore the product to its normal operation.
 - e) If the product has been dropped or damaged in any way, and
 - f) When the product exhibits a distinct change in performance - this indicates a need for service.
22. Battery shall not be exposed to excessive heat such as sunshine, fire or the like.
23. **CAUTION**
Danger of explosion if battery is incorrectly replaced. Replace only with the same or equivalent type.



This symbol indicates that this product incorporates double insulation between hazardous mains voltage and user accessible parts.



CAUTION:
TO PREVENT ELECTRIC SHOCK, MATCH WIDE BLADE OF PLUG TO WIDE SLOT, FULLY INSERT THE PLUG TO MAIN POWER SOCKET.

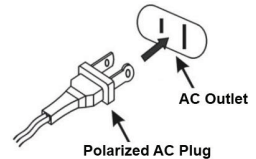

SAVE THESE INSTRUCTIONS

IMPORTANT NOTE

Avoid installing the unit in locations described below:

- Places exposed to direct sunlight or close to heat radiating appliances such as electric heaters.
- Places subject to constant vibration.
- Dusty, humid or moist places.
- Sources of electrical noise such as fluorescent lamps or motors.
- In case of malfunction due to electrostatic discharge, the apparatus has to be reset by disconnecting it from mains supply and removing all the batteries. Wait at least for 30 seconds before reconnect the AC power cord or reinstall the batteries.

CAUTION

CLASS 1 LASER PRODUCT

CLASS 1 LASER PRODUCT
APPAREIL LASER DE CLASSE 1
PRODUCTO LASER DE CLASE 1

CAUTION
INVISIBLE LASER RADIATION
WHEN OPEN AND INTERLOCKS
DEFEATED
AVOID EXPOSURE TO BEAM.



This product contains a low power laser device.

Note: This product complies with DHHS rule 21 CFR, subchapter J, Part 1040 at the date of manufacture.

Follow the advice below for safe operations.

ON PROTECTION AGAINST LASER ENERGY EXPOSURE

- As the laser beam used in this compact disc player is harmful to the eyes, do not attempt to disassemble the casing.
- Stop operation immediately if any liquid or solid object should fall into the cabinet.
- Do not touch the lens or poke at it. If you do, you may damage the lens and the player may not operate properly.
- Do not put anything in the safety slot. If you do, the laser diode will be ON when the CD door is still open.
- This unit employs a laser. The use of controls or adjustment or performance of procedures other than those specified here may result in exposure to hazardous radiation.

ON PLACEMENT

- Do not use the unit in places which are extremely hot, cold, dusty, or humid.
- Place the unit on a flat and even surface.
- Do not restrict the air flow of the unit by placing it in a place with poor air flow, by covering it with a cloth, or by placing it on a carpet.

ON SAFETY

- When connecting and disconnecting the AC power, grip the AC cord plastic plug and not the cord itself. Pulling the cord may damage it and create hazard.
- When you are not going to use the unit for a long period of time, disconnect the AC power cord from the wall outlet and remove all batteries.

ON AC VOLTAGE

- Before use, check that the rated voltage of your unit matches your local voltage.

ON CONDENSATION

- When left in a heated room where it is warm and damp, water droplets or condensation may form inside the CD player.
- When there is condensation inside the unit, the unit may not function normally.
- Let it stand for 1 to 2 hours before turning the power on, or gradually heat the room up and dry the unit before use.

Should any trouble occur, disconnect the AC power cord and refer servicing to qualified personnel.

COMPLIANCE WITH FCC REGULATIONS

This device complies with Part 15 of the FCC Rules. Operation is subject to the following two conditions:

- (1) This device may not cause harmful interference, and
- (2) This device must accept any interference received, including interference that may cause undesired operation.

This equipment has been tested and found to comply with the limits for a Class B Digital Device, pursuant to Part 15 of the FCC Rules. These limits are designed to provide reasonable protection against harmful interference in a residential installation. This equipment generates, uses and can radiate radio frequency energy and, if not installed and used in accordance with the instructions, may cause harmful interference to radio communications. However, there is no guarantee that interference will not occur in a particular installation. If this equipment does cause harmful interference to radio or television reception, which can be determined by turning the equipment off and on, the user is encouraged to try to correct the interference by one or more of the following measures:

- Reorient or relocate the receiving antenna.
- Increase the separation between the equipment and receiver.
- Connect the equipment into an outlet on a circuit different from that to which the receiver is connected.
- Consult the dealer or an experienced radio/TV technician for help.

WARNING

Changes or modifications to this unit not expressly approved by the party responsible for compliance could void the user's authority to operate the equipment.

PROTECT YOUR FURNITURE

This model is equipped with non-skid rubber 'feet' to prevent the product from moving when you operate the controls. These 'feet' are made from non-migrating rubber material specially formulated to avoid leaving any marks or stains on your furniture. However certain types of oil based furniture polishes, wood preservatives, or cleaning sprays may cause the rubber 'feet' to soften, and leave marks or a rubber residue on the furniture. To prevent any damage to your furniture we strongly recommend that you purchase small self-adhesive felt pads, available at hardware stores and home improvement centers everywhere, and apply these pads to the bottom of the rubber 'feet' before you place the product on fine wooden furniture.

LOCATION OF CONTROLS

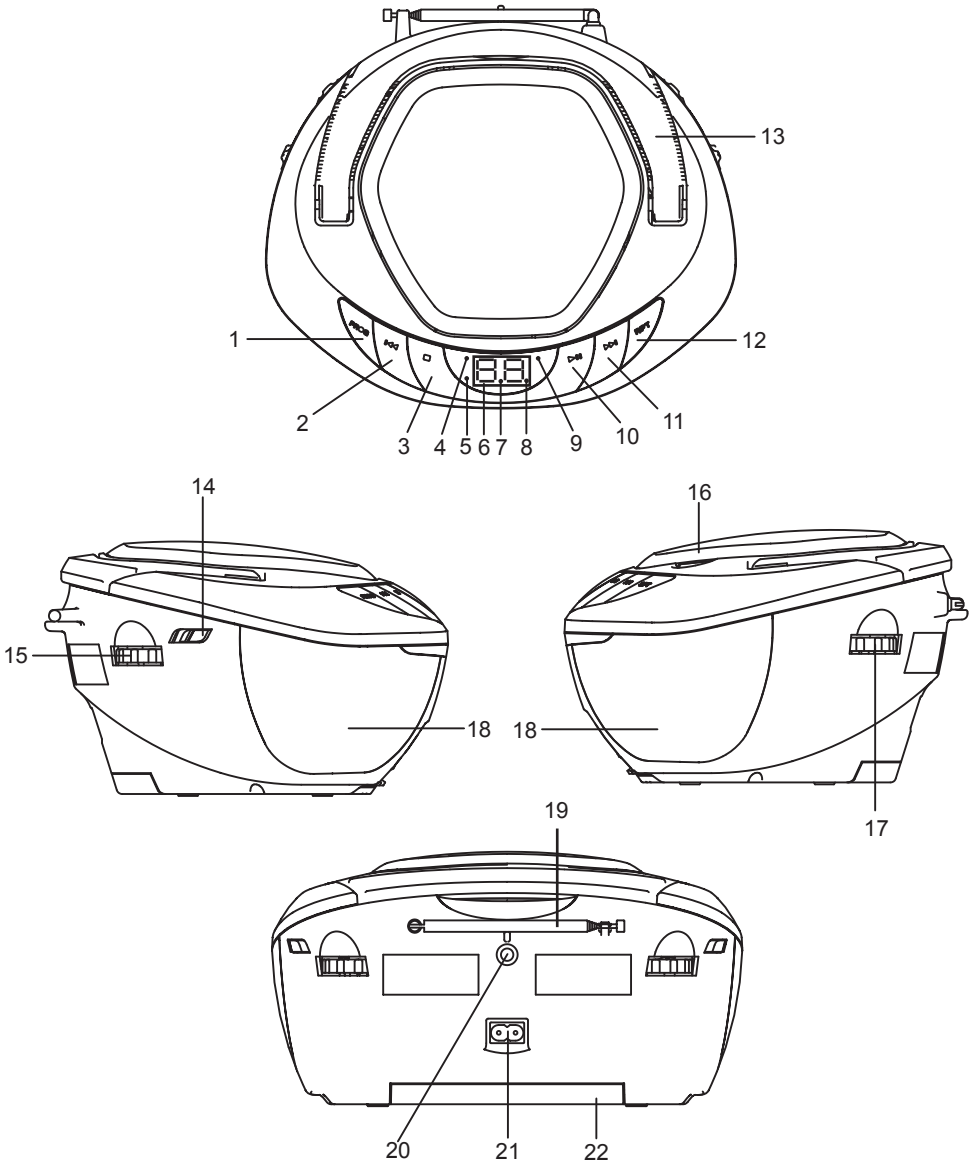

1. Program (PROG) Button	12. Repeat (RPT) Button
2. Skip/Search Backward ⏮ Button	13. Carrying Handle
3. Stop ■ Button	14. Function Switch (AM/FM/CD/Off)
4. Power Indicator	15. Volume Control Knob
5. FM Stereo Indicator	16. CD Door
6. LED Display	17. Tuning Control Knob
7. PROG Indicator	18. Speakers
8. Repeat Indicator	19. Telescopic Antenna
9. PLAY/PAUSE Indicator	20. AUX IN Jack
10. Play/Pause ▶ Button	21. AC Power Jack
11. Skip/Search Forward ▶▶ Button	22. Battery Compartment Door

POWER SOURCES

This unit operates on 120V~ 60Hz or 6 x DC1.5V “C” (UM-2) batteries. Do not attempt to operate the unit on any other power source. You could cause damage to the unit and void your warranty. Please be sure the power outlet you plug this unit into is working and receives constant (unswitched) power.

AC OPERATION

Plug the detachable AC cord into a standard AC outlet (120V~60Hz).

1. When the AC power cord (included) is connected to the AC Power Socket on the back of the unit and the other end is plugged into a 120V AC~ 60Hz wall outlet, the unit will disconnect the batteries automatically, and operate on AC Power only.
2. Slide the FUNCTION SWITCH to “CD” for CD / AUX play, “FM” for FM radio, “AM” for AM radio and “OFF” for unit power off.

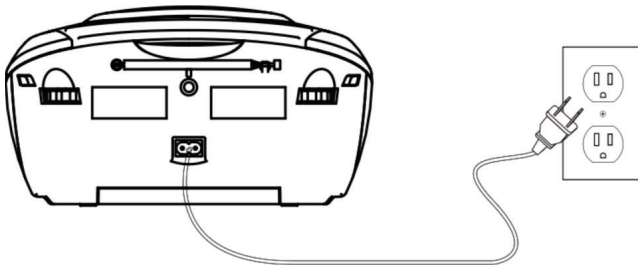

WARNING:

- Before connecting to the power outlet, ensure that the outlet corresponds to the information on the rating label at the back of the apparatus.

BATTERY OPERATION

1. Remove the BATTERY DOOR.
2. Install 6 x DC1.5V “C” (UM-2) batteries (not included) according to the polarity diagram inside the battery compartment.
Note: For best performance, alkaline-type batteries are recommended.
3. Close the BATTERY DOOR.

IMPORTANT: Be sure that the batteries are installed correctly. Wrong polarity may damage the unit and void the warranty.

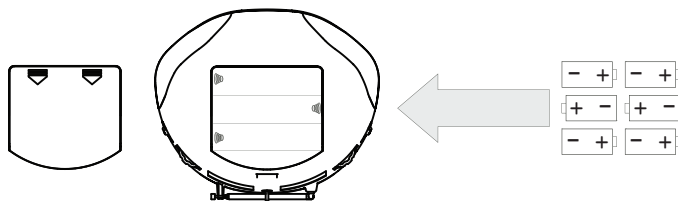

⚠ BATTERY NOTE AND CARE

1. Danger of explosion if the battery is replaced incorrectly. Replace only with the same or equivalent type
2. Do not mix old and new batteries.
3. Do not mix alkaline, standard (carbon-zinc) or rechargeable (nickel-cadmium) batteries.
4. If the unit is not to be used for an extended period of time, remove the batteries. Old or leaking batteries can cause damage to the unit and may void the warranty.
5. Do not try to recharge batteries not intended to be recharged; they can overheat and rupture. (Follow battery manufacturer's directions).
6. Do not dispose of batteries in fire, batteries may leak or explode.

BATTERY REPLACEMENT

When the output sound of this unit becomes distorted or the CD player operation appears unstable, the batteries are weak. You need to replace all the exhausted batteries at the same time as soon as possible to avoid battery leakage.

RADIO OPERATION

1. Slide the FUNCTION SWITCH to AM or FM position.
2. Rotate the TUNING CONTROL KNOB to your desired radio station according to the DIAL SCALE on the knob.
3. Rotate the VOLUME CONTROL KNOB to adjust to the desired output level.
4. To turn off the radio, slide the FUNCTION SWITCH to "OFF" position.

TIPS FOR BEST RECEPTION

AM – The AM antenna is located inside the cabinet of the unit. If AM reception is weak, change the position of unit until the internal antenna picks up the strongest signal.

FM – If a stereo broadcast program is being received, the FM STEREO INDICATOR will light. During FM or FM Stereo reception, always keep the FM TELESCOPIC ANTENNA fully extended for best performance. However, if FM reception is weak, try repositioning the unit near an open window until you get the best reception.

CD OPERATION

NOTE: This unit not only plays commercial compact discs but also self-complied CD-RW discs.

- Because of non-standardized format definition/production of CD-R/RW, playback quality & performance is not guaranteed.
- Manufacturer is not responsible for the playability of CD-R/RW due to recording conditions such as PC performance, writing software, media properties etc.
- Do not attach a label or seal to either side of the CD-R/RW disc. It may cause a malfunction.

PLAY MODE

1. Slide the FUNCTION SWITCH to the "CD" position.
2. Open the CD DOOR, load a CD with the label side facing upward and then close the CD door.

3. Disc information (total number of tracks) will appear on the LED DISPLAY.
4. Press PLAY/PAUSE ►|| BUTTON to start playing the CD, the PLAY/PAUSE INDICATOR will light steadily.
5. While playing, press the PLAY/PAUSE ►|| BUTTON to pause, the PLAY/PAUSE INDICATOR will flash. Press PLAY/PAUSE ►|| BUTTON again to resume playing.
6. Adjust the VOLUME CONTROL KNOB to the desired volume level.
7. Press STOP ■ BUTTON to stop playing.
8. To turn off the CD player, slide the FUNCTION SWITCH to "OFF".

NOTE: If skipping occurs during CD play, try turning the volume down.
Do not open the CD DOOR when a CD is playing.

REPEAT MODE

Repeat 1

When the REPEAT BUTTON is pressed once, the REPEAT INDICATOR will light and blink continuously. The current track will be repeated until it is interrupted.

Repeat All

When the REPEAT BUTTON is pressed twice, the REPEAT INDICATOR will light steadily. The whole disc will be played continuously.

To Cancel Repeat Function: Press the REPEAT BUTTON until the REPEAT INDICATOR is off.

SKIP AND SEARCH MODE

1. During Play or Pause mode, tap the SKIP FORWARD "►►" or SKIP BACKWARD "◄◄" BUTTON to go to the next track or go back to the beginning of the current track.
2. During play mode or Pause mode, press and hold the SEARCH FORWARD "►►" or SEARCH BACKWARD "◄◄" BUTTON to search within the current track with audible high speed playback.

PROGRAM PLAY MODE

This function allows music tracks to be played in a programmed sequence.

NOTE: Program can only be set in STOP mode.

1. Press the PROGRAM BUTTON once. "01" in the LED DISPLAY and PROGRAM INDICATOR both will flash.
2. Press the SKIP FORWARD "►►" or SKIP BACKWARD "◄◄" BUTTON to select the track to be programmed.
3. Press the PROGRAM BUTTON again to store the selection. The LED DISPLAY will advance to "02" and flash to prompt for the next input.
4. You may repeat steps #2 to #3 to program up to 20 tracks. As soon as you have entered the 20th track, the LED DISPLAY will automatically show the programmed tracks one by one in their correct sequence starting from the first. At the end of program review, "01" in the LED DISPLAY and PROGRAM INDICATOR will both flash.
5. Press the PLAY ►|| BUTTON to complete and start program play. The PROGRAM INDICATOR will light. Press the STOP ■ BUTTON to stop.
6. Normally all the programmed tracks will be played through once and then stop. However, you may use the REPEAT function to repeatedly play a certain track (Repeat 1) or all tracks in the program (Repeat All). You may also tap SKIP Forward "►►" BUTTON to go directly to other tracks ahead or use SKIP BACKWARD "◄◄" BUTTON to go back to previous track(s) during program play.
7. To review/edit the programmed tracks during play, press the STOP ■ BUTTON and then the PROGRAM BUTTON, "01" will show in the LED DISPLAY and PROGRAM INDICATOR will both flash. If you do not want to change any track in the program, press STOP ■ BUTTON.
8. To edit a programmed track, use the SKIP FORWARD "►►" or SKIP BACKWARD "◄◄" BUTTON to select a new track and press PROGRAM BUTTON to confirm. To skip forward, press PROGRAM BUTTON until you reach the program number whose track you want to change.

9. To cancel program play, press the STOP ■ BUTTON twice while program playback is running or open the CD DOOR in stop mode. The PROGRAM INDICATOR will go off.

AUX IN OPERATION

This CD features an AUX-IN jack for connecting your iPod, MP3 player or other digital music player.

1. Connect the headphone jack of your external device to the AUX IN jack located on the back of this CD player (The connection cable is not included).
2. Turn on the CD player and it will enter the AUX function mode once an external device is plugged into the AUX IN jack.
3. Start to play your iPod, MP3 player or other external audio device.
4. Slowly adjust both volume controls on your CD player and the external device.
5. Turn off your iPod, MP3 player and etc. when finish listening. Turn the CD player off and unplug the AUX IN jack.

Remark: Once the AUX IN jack is plugged, the CD player will automatically enter the AUX mode when the FUNCTION SWITCH is in CD mode. Remember to disconnect the cable from the unit after use in order to be able to listen to the CD player again.

CARE AND MAINTENANCE

1. Children should be supervised when using this appliance.
2. Never wrap the earbuds lead around any animal or person. Special care should be taken with long wires.
3. Clean your unit with a damp (never wet) cloth. Solvent or detergent should never be used.
4. Avoid leaving your unit in direct sunlight or in hot, humid or dusty places.
5. Keep your unit away from heating appliances and sources of electrical noise such as fluorescent lamps or motors.
6. If drop-outs or interruptions occur in the music during CD play, or if the CD fails to play at all, its bottom surface may require cleaning. Before playing, wipe the disc from the center outwards with a good soft cleaning cloth.



TROUBLESHOOTING GUIDE

Symptom	Possible Cause	Solution
Noise or sound distorted on AM or FM broadcast	<ul style="list-style-type: none"> - Station not tuned properly for AM or FM. - FM: FM telescopic antenna is not extended. - AM: The bar antenna is not positioned correctly 	<ul style="list-style-type: none"> - Retune the AM or FM broadcast station. - FM: Extend FM telescopic antenna. - AM: Reposition the unit until the best reception is obtained.
AM or FM no sound	<ul style="list-style-type: none"> - Unit not in "RADIO" function mode. - Volume set at minimum 	<ul style="list-style-type: none"> - Slide FUNCTION SWITCH to "RADIO" position. - Increase Volume.
CD player will not play	<ul style="list-style-type: none"> - Unit not in CD function mode. - CD is not loaded properly. - If the CD is self-compiled, the media used may not be compatible with the player. 	<ul style="list-style-type: none"> - Select CD function mode. - Load CD with label side up. - Use better quality blank media and retest.
CD skips while playing	<ul style="list-style-type: none"> - Disc is dirty or scratched. 	<ul style="list-style-type: none"> - Wipe CD with clean cloth or use another disc.
Intermittent sound from CD player	<ul style="list-style-type: none"> - Dirty or defective disc - Dirty pick up lens - Player is subject to excessive shock or vibration 	<ul style="list-style-type: none"> - Clean or replace the defective disc. - Use a CD lens cleaning disc to clean the lens. - Relocate the player away from shock or vibration.
Sound appears distorted at high volume setting	<ul style="list-style-type: none"> - Volume control is set to maximum. 	<ul style="list-style-type: none"> - Adjust Volume control to a lower comfortable level.

SPECIFICATIONS

Frequency Range: AM 530 - 1710 kHz
 FM 88 - 108 MHz
 Power Sources: 120V~ 60Hz 14W or
 6 x DC1.5V 'C' (UM-2) Batteries (Not included)



At Spectra, environmental and social responsibility is a core value of our business. We are dedicated to continuous implementation of responsible initiatives with an aim to conserve and maintain the environment through responsible recycling.

Please visit us at <http://www.spectrainl.com/green.htm> for more information on Spectra's green initiatives or to find a recycler in your area.

90 DAY LIMITED WARRANTY AND SERVICE VALID IN THE U.S.A ONLY

SPECTRA MERCHANDISING INTERNATIONAL, INC. warrants this unit to be free from defective materials or factory workmanship for a period of 90 days from the date of original customer purchase and provided the product is utilized within the U.S.A. This warranty is not assignable or transferable. Our obligation under this warranty is the repair or replacement of the defective unit or any part thereof, except batteries, when it is returned to the SPECTRA Service Department, accompanied by proof of the date of original consumer purchase, such as a duplicate copy of a sales receipt.

You must pay all shipping charges required to ship the product to SPECTRA for warranty service. If the product is repaired or replaced under warranty, the return charges will be at SPECTRA's expense. There are no other express warranties other than those stated herein.

This warranty is valid only in accordance with the conditions set forth below:

1. The warranty applies to the SPECTRA product only while:
 - a. It remains in the possession of the original purchaser and proof of purchase is demonstrated.
 - b. It has not been subjected to accident, misuse, abuse, improper service, usage outside the descriptions and warnings covered within the user manual or non-SPECTRA approved modifications.
 - c. Claims are made within the warranty period.
2. This warranty does not cover damage or equipment failure caused by electrical wiring not in compliance with electrical codes or SPECTRA user manual specifications, or failure to provide reasonable care and necessary maintenance as outlined in the user manual.
3. Warranty of all SPECTRA products applies to residential use only and is void when products are used in a nonresidential environment or installed outside the United States.

This warranty gives you specific legal rights, and you may also have other rights which vary from state to state. TO OBTAIN SERVICE please remove all batteries (if any) and pack the unit carefully and send it freight prepaid to SPECTRA at the address shown below. IF THE UNIT IS RETURNED WITHIN THE WARRANTY PERIOD shown above, please include a proof of purchase (dated cash register receipt) so that we may establish your eligibility for warranty service and repair of the unit without cost. Also include a note with a description explaining how the unit is defective. A customer service representative may need to contact you regarding the status of your repair, so please include your name, address, phone number and email address to expedite the process.

IF THE UNIT IS OUTSIDE THE WARRANTY PERIOD, please include a check for \$12.00 to cover the cost of repair, handling and return postage. All out of warranty returns must be sent prepaid.

It is recommended that you contact SPECTRA first at 1-800-777-5331 or by email at custserv@spectraintrl.com for updated information on the unit requiring service. In some cases the model you have may be discontinued, and SPECTRA reserves the right to offer alternative options for repair or replacement.

SPECTRA MERCHANDISING INTERNATIONAL, INC.
4230 North Normandy Avenue,
Chicago, IL60634, USA.
1-800-777-5331

To register your product, visit the link on the website below to enter your information.
<http://www.spectraintrl.com/wform.htm>